

REVISIONS			
REV	DESCRIPTION	DATE	APPROVED
A	AR SANDBOX	10/2012	

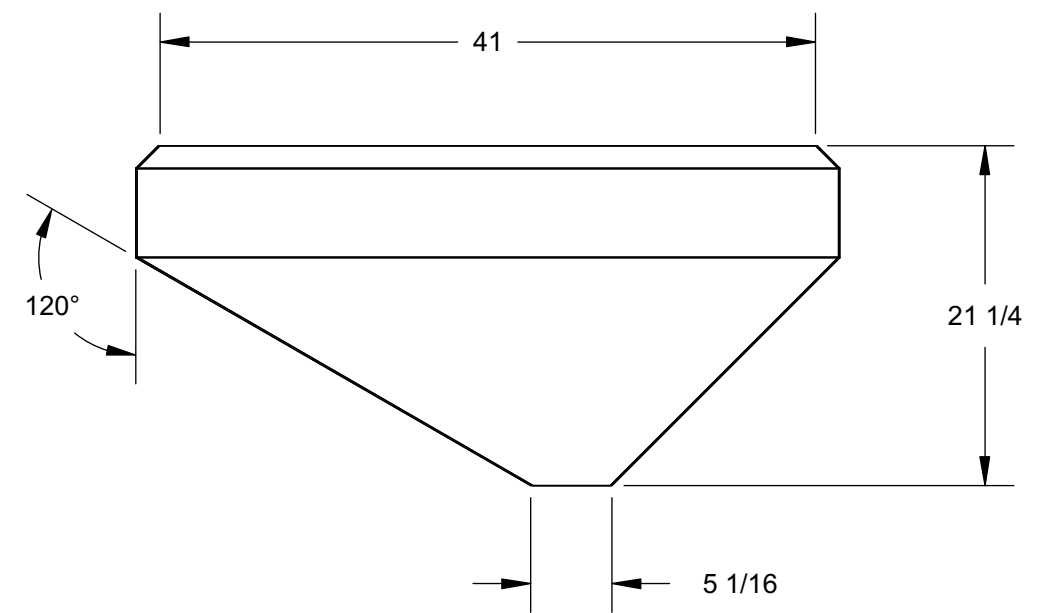
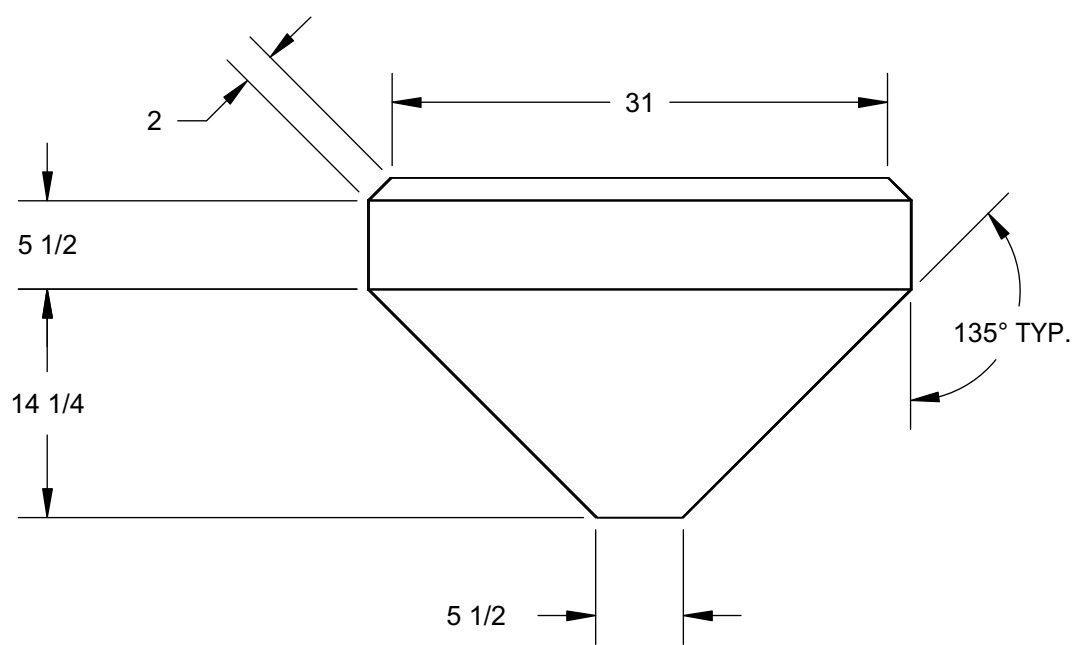
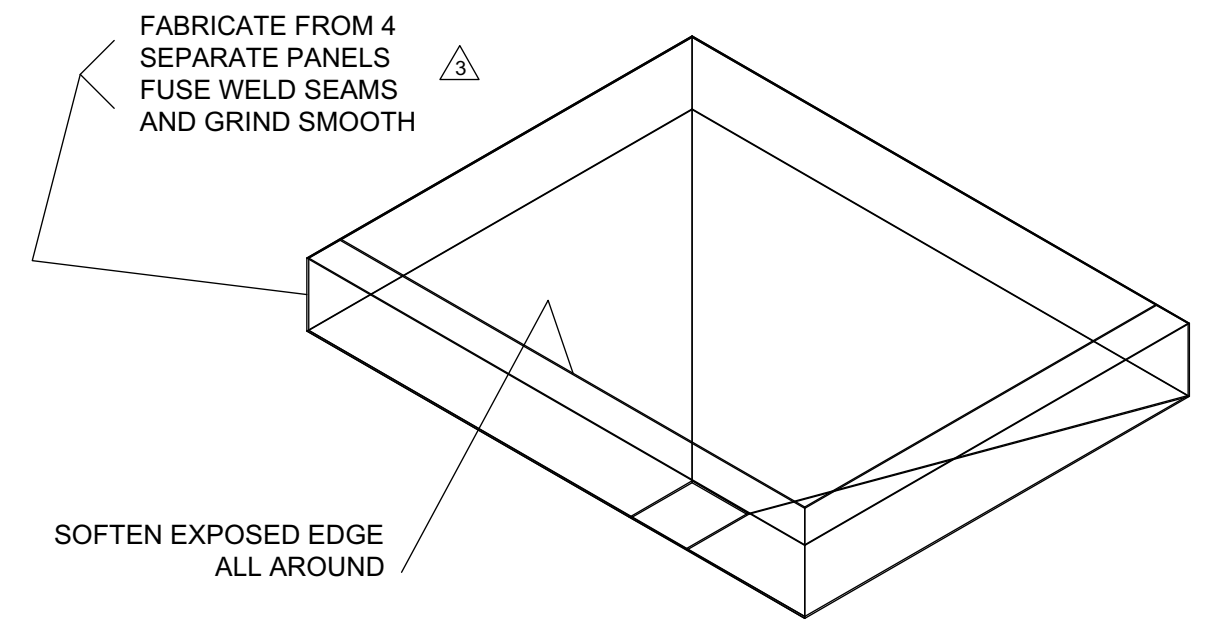
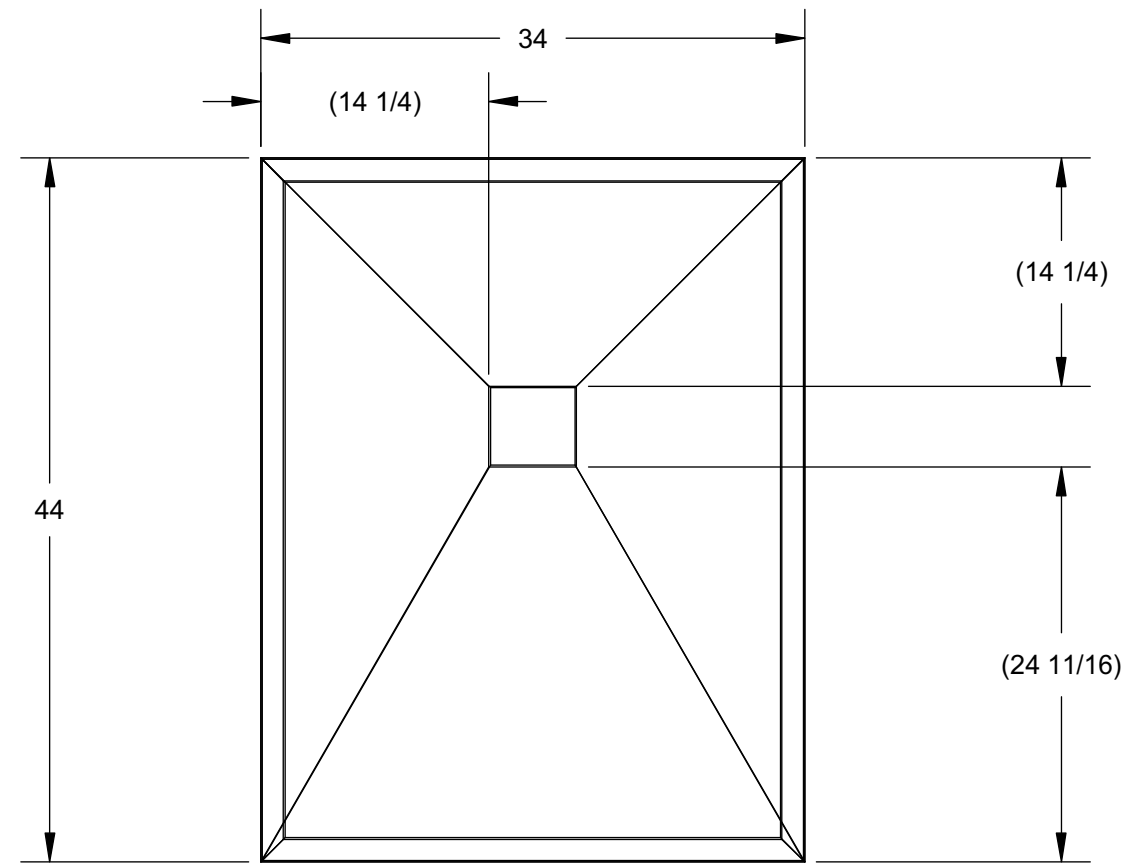

- NOTES:
1. INTERPRET DRAWING PER ANSI Y14.5.
  2. REMOVE BURRS AND SHARP EDGES UNLESS SPECIFIED OTHERWISE
  3. DOES NOT NEED TO BE WATERTIGHT. SEE PAGE 2 FOR FLAT LAYOUTS
  - 4.

DRAWN Aaron Handler	DATE 10/2012	<b>THE EXPLORATORIUM</b>	
UNLESS OTHERWISE SPECIFIED DIMENSIONS ARE IN INCHES. AND TOLERANCES ARE: DEC .XXX +/- .005 DEC .XX +/- .01 FRAC +/- 1/32 ANGLE +/- 1°	CHECKED	DATE	TITLE <b>UPPER SHELL</b>
DIMENSIONAL LIMITS APPLY BEFORE PLATING DO NOT SCALE THIS DRAWING	APPROVED	DATE	SIZE <b>B</b>
	FINISH	SCALE <b>1" = 1'</b>	MATERIAL <b>14ga MILD STEEL</b>
		DWG. NO. <b>1260-3-1-01</b>	REV <b>A</b>
		SHEET OF <b>1 2</b>	

NOTE: DO NOT CUT OR PERFORATE  
ALONG DASHED LINES.  
LINES ARE FOR BENDING  
REFERENCE ONLY.

REVISIONS			
REV	DESCRIPTION	DATE	APPROVED
A	AR SANDBOX	10/2012	

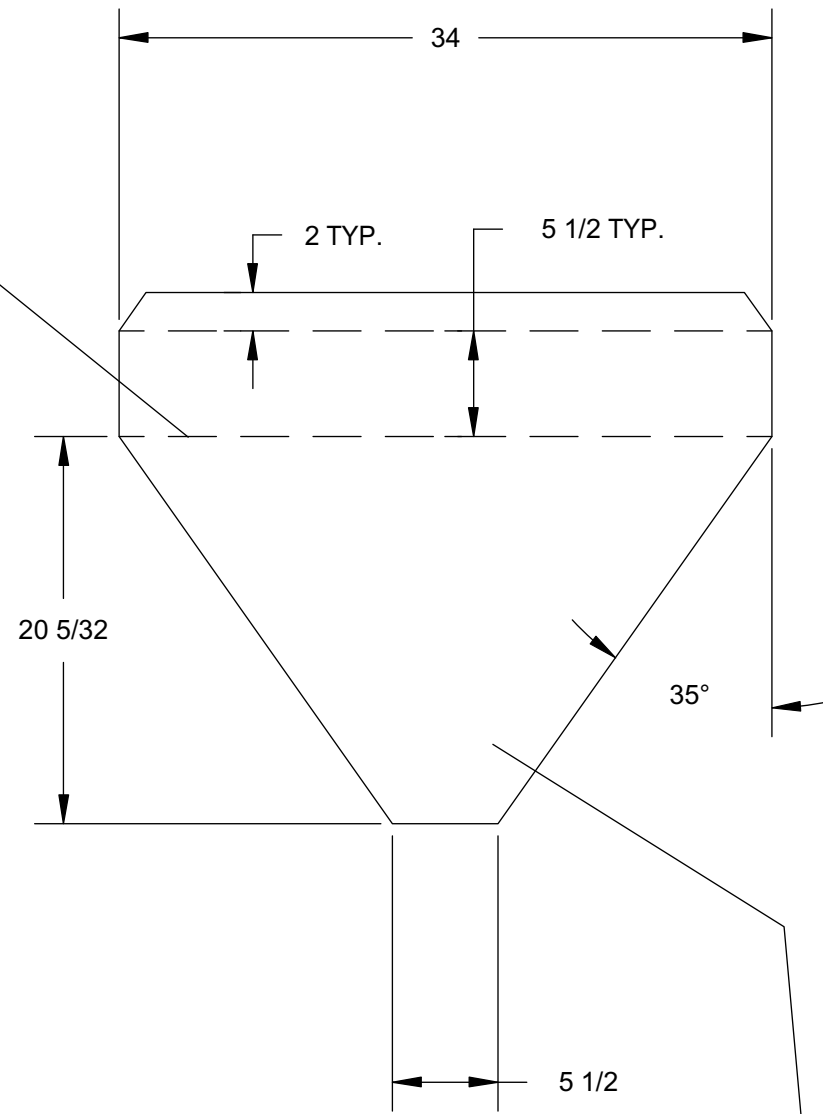

1 EACH

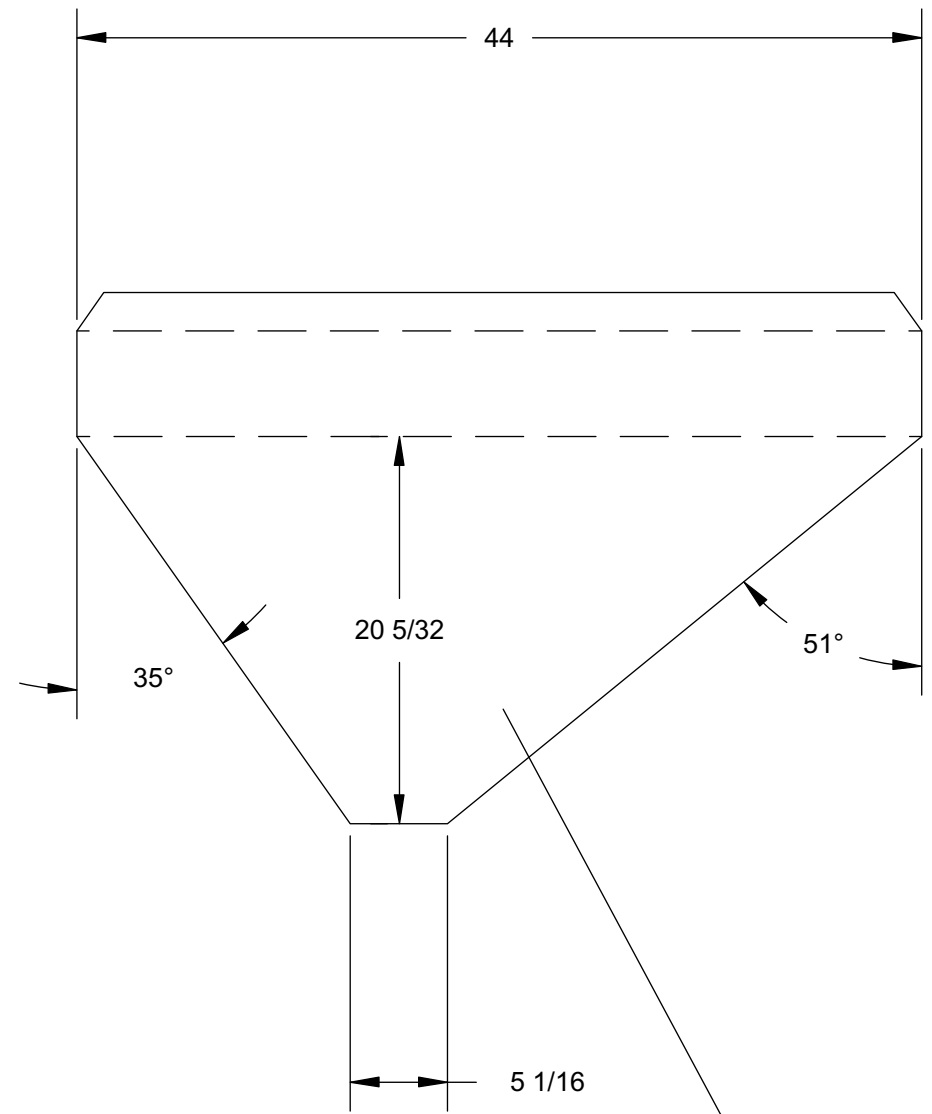

2 EACH  
(MIRROR BEND DIRECTION  
FOR PROPER ASSEMBLY)

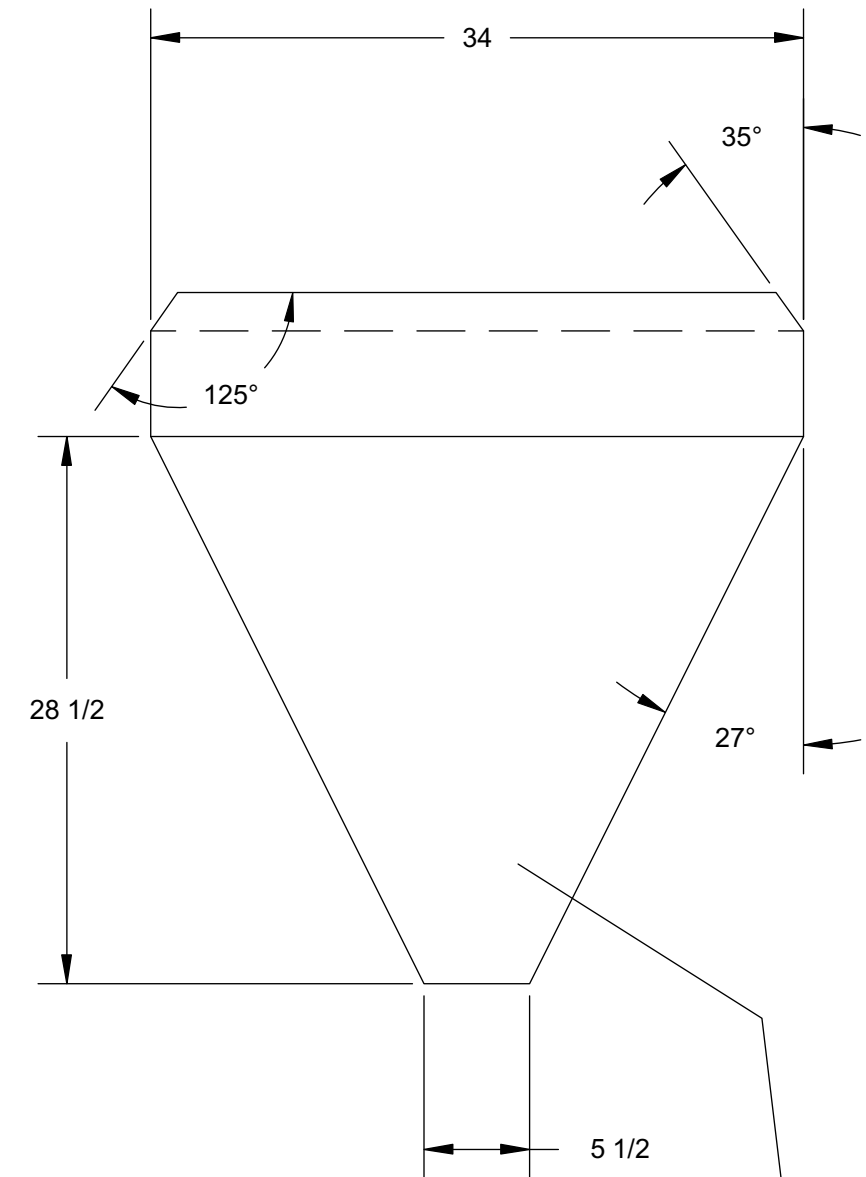

1 EACH

- NOTES:
1. INTERPRET DRAWING PER ANSI Y14.5.
  2. REMOVE BURRS AND SHARP EDGES UNLESS SPECIFIED OTHERWISE



DRAWN Aaron Handler	DATE 10/2012	THE EXPLORATORIUM	
UNLESS OTHERWISE SPECIFIED DIMENSIONS ARE IN INCHES. AND TOLERANCES ARE: DEC .XXX +/- .005 DEC .XX +/- .01 FRAC +/- 1/32 ANGLE +/- 1°	CHECKED	DATE	TITLE UPPER SHELL FLAT LAYOUTS
DIMENSIONAL LIMITS APPLY BEFORE PLATING DO NOT SCALE THIS DRAWING	APPROVED	DATE	SIZE B
	MATERIAL 14ga MILD STEEL	DWG. NO. 1260-3-1-01	REV A
	FINISH	SCALE 1" = 8"	SHEET OF 2 2

REVISIONS			
REV	DESCRIPTION	DATE	APPROVED
A	AR SANDBOX	10/2012	

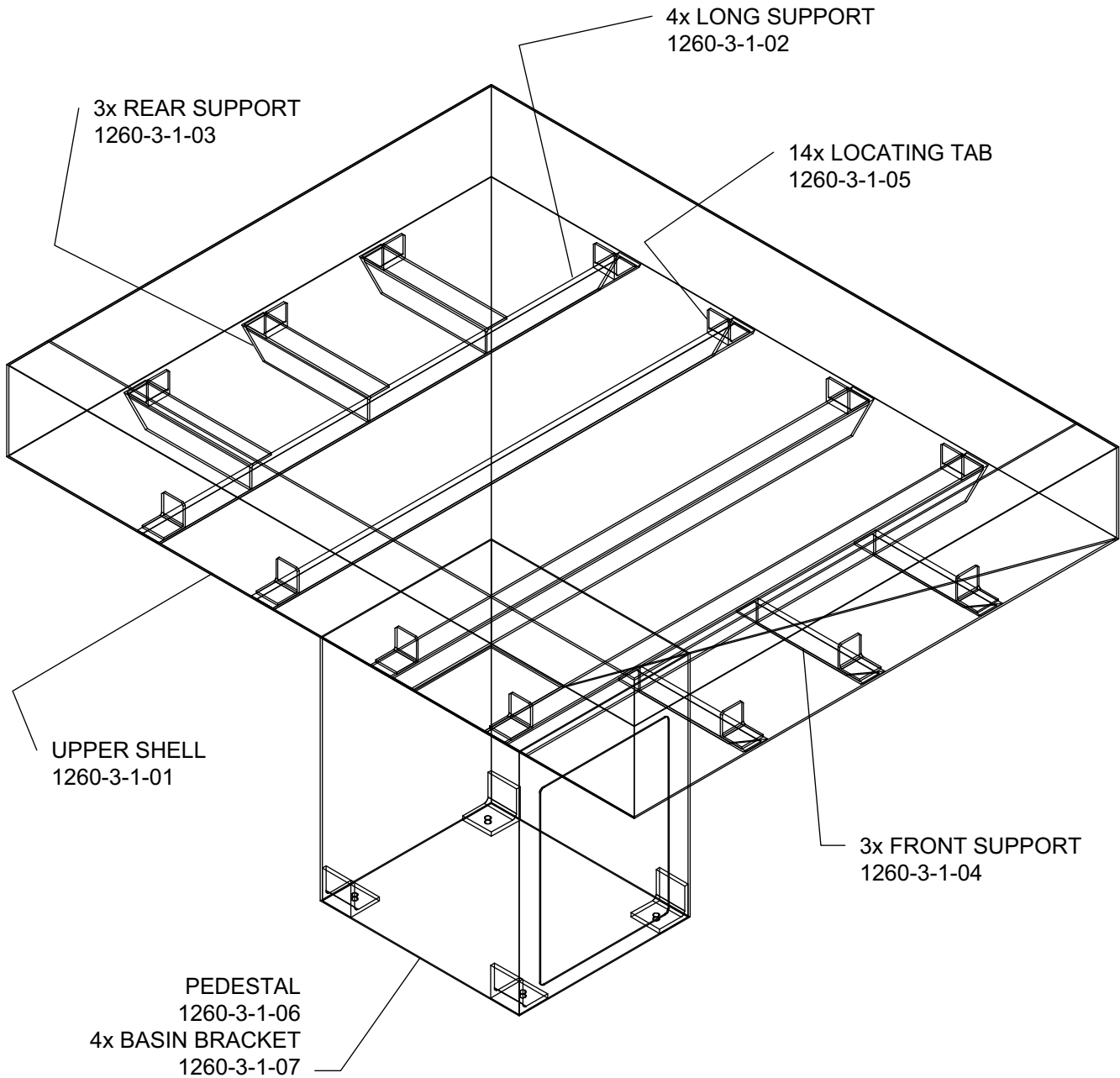

**NOTES:**

1. INTERPRET DRAWING PER ANSI Y14.5.
2. REMOVE BURRS AND SHARP EDGES UNLESS SPECIFIED OTHERWISE



DRAWN Aaron Handler		DATE 10/2012		 <b>THE EXPLORATORIUM</b>	
UNLESS OTHERWISE SPECIFIED DIMENSIONS ARE IN INCHES. AND TOLERANCES ARE:		CHECKED	DATE		
DEC .XXX +/- .005		APPROVED	DATE	MATERIAL <b>STEEL</b>	
DEC .XX +/- .01		FINISH <b>POWDERCOAT</b>		SIZE <b>A</b>	DWG. NO. <b>1260-3-1</b>
FRAC +/- 1/32		SCALE <b>1" = 8"</b>		REV <b>A</b>	SHEET OF <b>1 2</b>
ANGLE +/- 1°		<small>THIS DOCUMENT, THE DATA AND INFORMATION DISCLOSED IN THIS DOCUMENT ARE CONFIDENTIAL AND ARE THE EXCLUSIVE PROPERTY OF THE EXPLORATORIUM. REPRODUCTION, COPYING, DISCLOSURE, OR THE USE OF THIS DOCUMENT, DATA OR INFORMATION WITHOUT THE WRITTEN PERMISSION OF THE EXPLORATORIUM IS PROHIBITED. ALL RIGHTS RESERVED.</small>			
DIMENSIONAL LIMITS APPLY BEFORE PLATING DO NOT SCALE THIS DRAWING					

REVISIONS			
REV	DESCRIPTION	DATE	APPROVED
A	AR SANDBOX	10/2012	

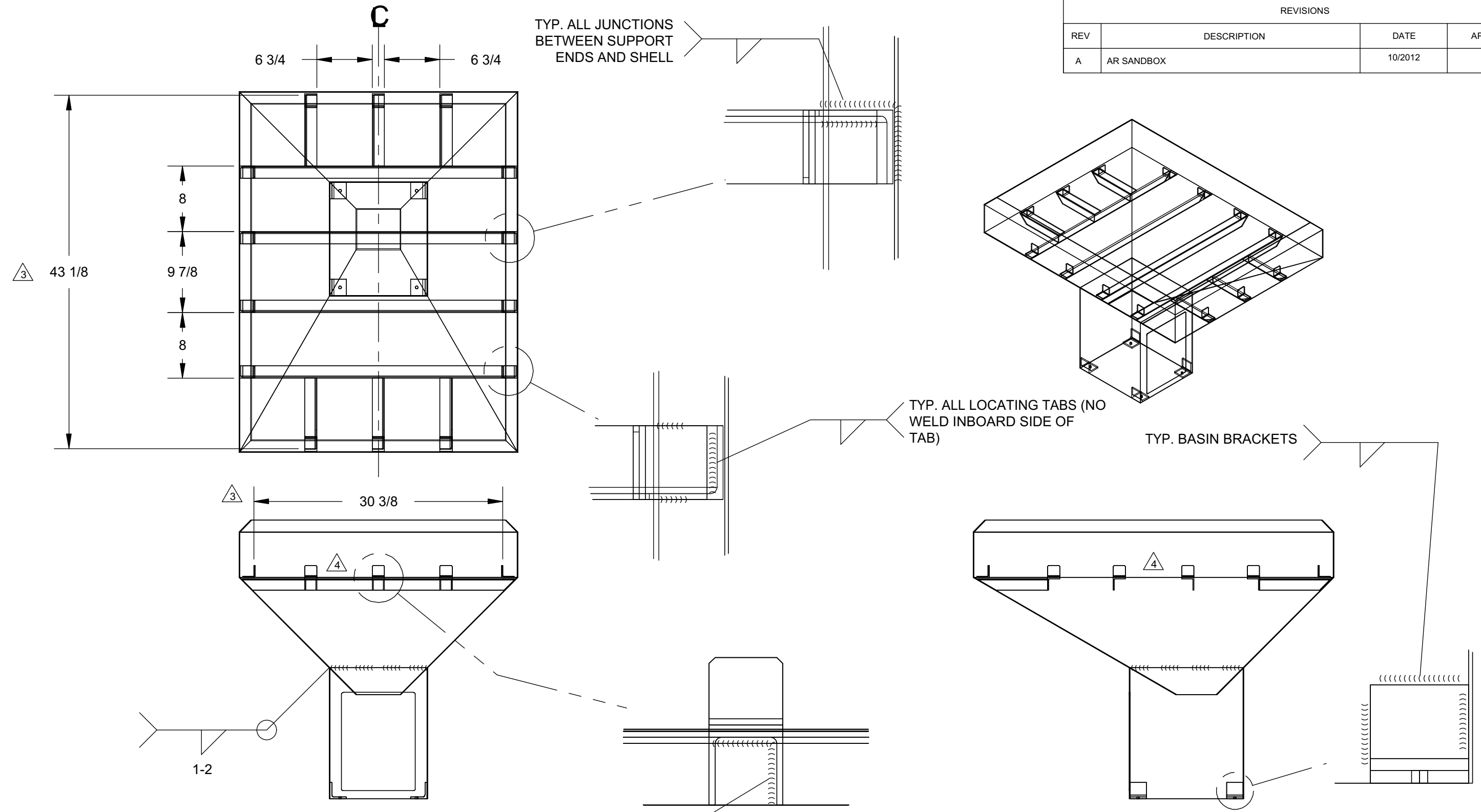

**NOTES:**

1. INTERPRET DRAWING PER ANSI Y14.5.
2. REMOVE BURRS AND SHARP EDGES UNLESS SPECIFIED OTHERWISE
3. CHECK FIT OF TROUGH 1260-3-3 BEFORE WELDING LOCATING TABS - 1/16" CLEARANCE AROUND OUTSIDE OF TROUGH
4. TOP SURFACES OF SUPPORT MEMBERS MUST BE COPLANAR

DRAWN Aaron Handler		DATE 10/2012		THE EXPLORATORIUM	
UNLESS OTHERWISE SPECIFIED DIMENSIONS ARE IN INCHES. AND TOLERANCES ARE: DEC .XXX +/- .005 DEC .XX +/- .01 FRAC +/- 1/32 ANGLE +/- 1°		CHECKED	DATE	TITLE BASIN WELDMENT	
DIMENSIONAL LIMITS APPLY BEFORE PLATING DO NOT SCALE THIS DRAWING		APPROVED	DATE	SIZE B	DWG. NO. 1260-3-1
		MATERIAL STEEL		SCALE 1" = 16"	REV A
		FINISH POWDERCOAT		SHEET OF 2 2	

REVISIONS			
REV	DESCRIPTION	DATE	APPROVED
A	AR SANDBOX	10/2012	

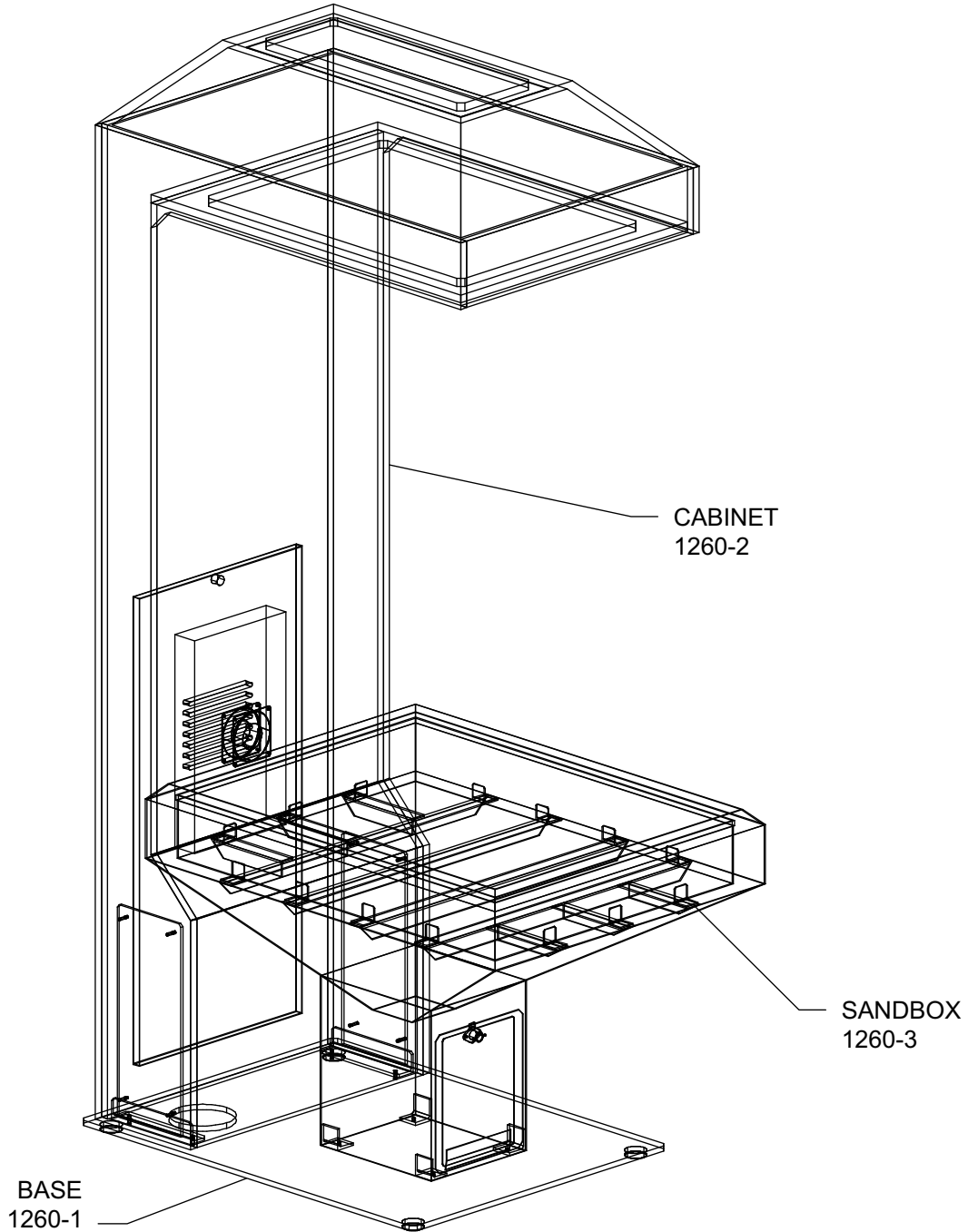

**NOTES:**

1. INTERPRET DRAWING PER ANSI Y14.5.
2. REMOVE BURRS AND SHARP EDGES UNLESS SPECIFIED OTHERWISE



DRAWN Aaron Handler		DATE 10/2012		 <b>THE EXPLORATORIUM</b>			
UNLESS OTHERWISE SPECIFIED DIMENSIONS ARE IN INCHES. AND TOLERANCES ARE: DEC .XXX +/- .005 DEC .XX +/- .01 FRAC +/- 1/32 ANGLE +/- 1°		CHECKED	DATE			TITLE <b>AUGMENTED REALITY SANDBOX</b>	
DIMENSIONAL LIMITS APPLY BEFORE PLATING DO NOT SCALE THIS DRAWING		APPROVED	DATE	MATERIAL	SIZE <b>A</b>	DWG. NO. <b>1260</b>	REV <b>A</b>
		FINISH	SCALE		<small>THIS DOCUMENT, THE DATA AND INFORMATION DISCLOSED IN THIS DOCUMENT ARE CONFIDENTIAL AND ARE THE EXCLUSIVE PROPERTY OF THE EXPLORATORIUM. REPRODUCTION, COPYING, DISCLOSURE, OR THE USE OF THIS DOCUMENT, DATA OR INFORMATION WITHOUT THE WRITTEN PERMISSION OF THE EXPLORATORIUM IS PROHIBITED. ALL RIGHTS RESERVED.</small>		SHEET OF <b>1</b> OF <b>2</b>

REVISIONS			
REV	DESCRIPTION	DATE	APPROVED
A	AR SANDBOX	10/2012	

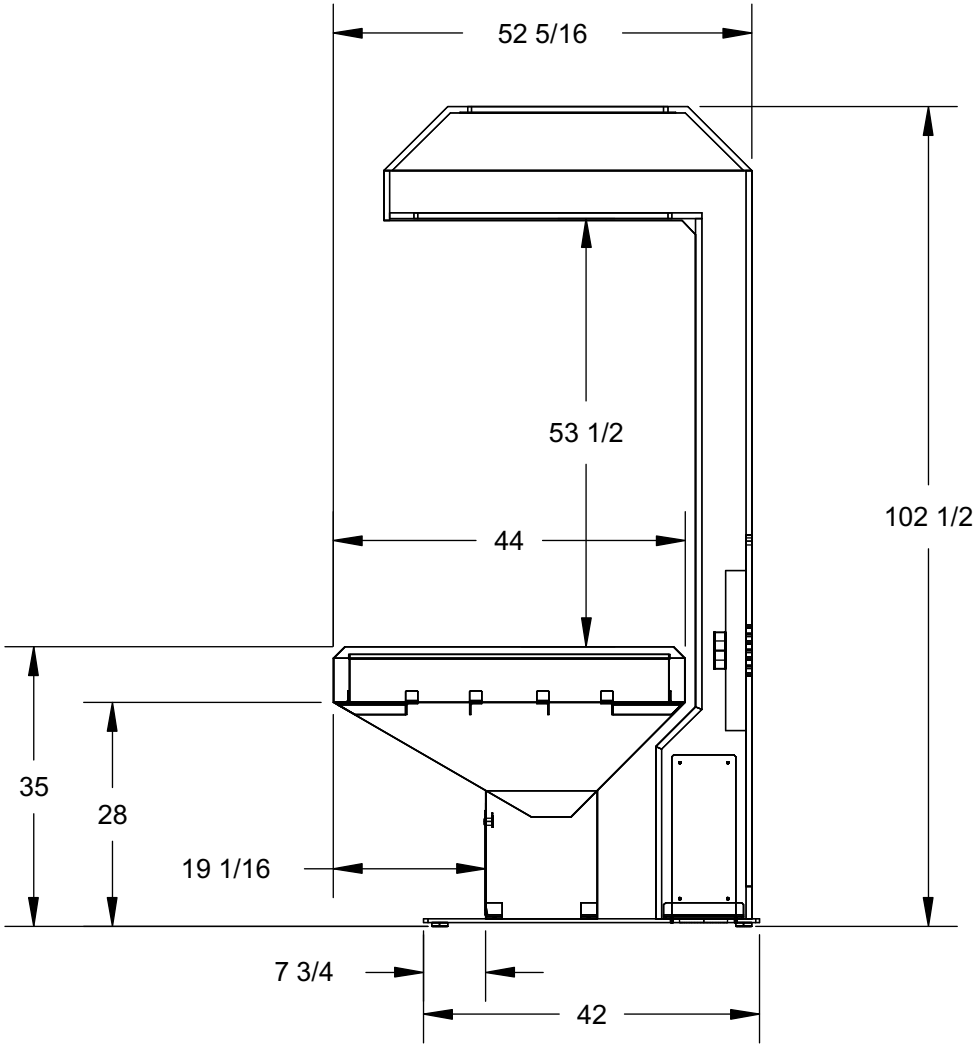
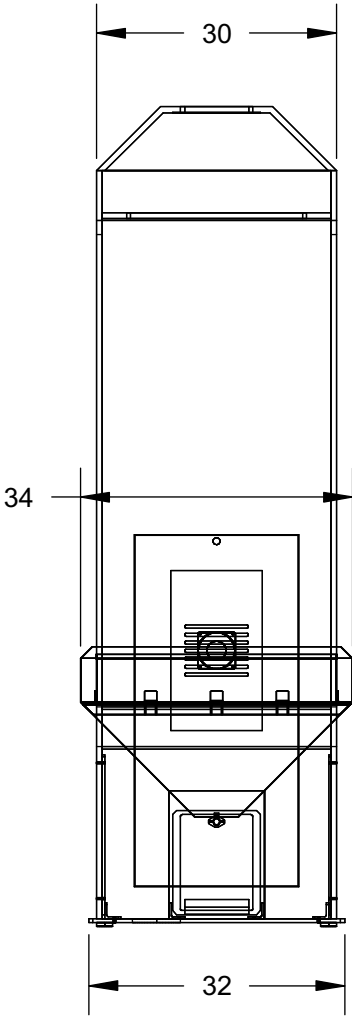

- NOTES:
1. INTERPRET DRAWING PER ANSI Y14.5.
  2. REMOVE BURRS AND SHARP EDGES UNLESS SPECIFIED OTHERWISE

- 3.
- 4.

DRAWN Aaron Handler		DATE 10/2012		 <b>THE EXPLORATORIUM</b>		
UNLESS OTHERWISE SPECIFIED DIMENSIONS ARE IN INCHES. AND TOLERANCES ARE: DEC .XXX +/- .005 DEC .XX +/- .01 FRAC +/- 1/32 ANGLE +/- 1°		CHECKED	DATE			TITLE <b>AUGMENTED REALITY SANDBOX</b>
DIMENSIONAL LIMITS APPLY BEFORE PLATING DO NOT SCALE THIS DRAWING		APPROVED	DATE	SIZE <b>A</b>	DWG. NO. <b>1260</b>	REV <b>A</b>
		FINISH		SCALE <b>1/2" = 1'</b>	<small>THIS DOCUMENT, THE DATA AND INFORMATION DISCLOSED IN THIS DOCUMENT ARE CONFIDENTIAL AND ARE THE EXCLUSIVE PROPERTY OF THE EXPLORATORIUM. REPRODUCTION, COPYING, DISCLOSURE, OR THE USE OF THIS DOCUMENT, DATA OR INFORMATION WITHOUT THE WRITTEN PERMISSION OF THE EXPLORATORIUM IS PROHIBITED. ALL RIGHTS RESERVED.</small>	
				SHEET OF	<b>2 2</b>	